

LaYR 2.0 Fixed Round Downlight



Installation Instruction Sheet

WARNING

To reduce the risk of death, injury or property damage from fire, electric shock, cuts, abrasions, falling parts and other hazards:

- Service of the equipment must be performed by qualified service personnel.
- Installation and maintenance must be performed by a person familiar with the construction and operation of this product and any hazards involved. All applicable codes and ordinances must be followed.
- Read this document before installing, servicing or maintaining this equipment. These instructions do not cover all installation, service and maintenance situations. If your situation is not covered, or, if you do not understand these instructions or additional information is required, contact Lux Illuminaire or your local agent.
- Read and follow all warnings and instructions provided by the LED manufacturer.

WARNING

- Before installing, servicing or maintaining this equipment, follow these general precautions. To reduce the risk of electrocution:
- Make sure the equipment is properly grounded.
- Always de-energize the circuit and/or equipment before connecting to, disconnecting from or servicing the equipment.

To prevent luminaire from over-current:

- By adding the input current of each luminaire section marked on the luminaire, the total current per power feed must not exceed the maximum line wire amperage marked on the luminaire and the power feed cord/wire amperage rating whichever is the least.

To reduce the risk of fire:

- Keep material away that can burn from hot LEDs.
- Make sure light engine is correctly installed.
- Use supply conductors with a minimum installation temperature rating as specified on equipment.

To reduce the risk of personal injury from cuts, abrasions or falling parts:

- Wear gloves to prevent cuts or abrasions from sharp edges when removing from carton, handling and maintaining this equipment.
- Do not use abrasive materials, glass cleaners or other solvents on reflector or lens. These substances may damage equipment and cause parts to eventually break and fall.
- Do not install a damaged fixture.

Tools required:

- Screwdriver: Philips #1, flathead 3/32" [2.5mm], and Torx T10 & T20 tips [DO NOT OVERTORQUE POWER DRIVER]
- Hammer [for fixing mounting bars into lumber installations]
- Drywall knife [for gypsum board installations]
- Saw, router, and/or adjustable hole cutter
- Pliers

LaYR 2.0 Fixed Round Downlight

Items List:

1. Remote Driver Box
2. IC/CP Box
3. Ceiling Pan
4. Mounting Bars (a) standard (b) optional Commercial bars with Butterfly Bracket
5. Stamped Ceiling Retention Ring
6. Light engine
7. Optional ceiling adaptor for ceilings thicker than 5/8" (a) 1" (b) 1.5"
8. Trim Ring
9. Baffle
10. Mud Plate [not required/supplied on MILL WORK]
11. Disposable Mud/Paint Plug

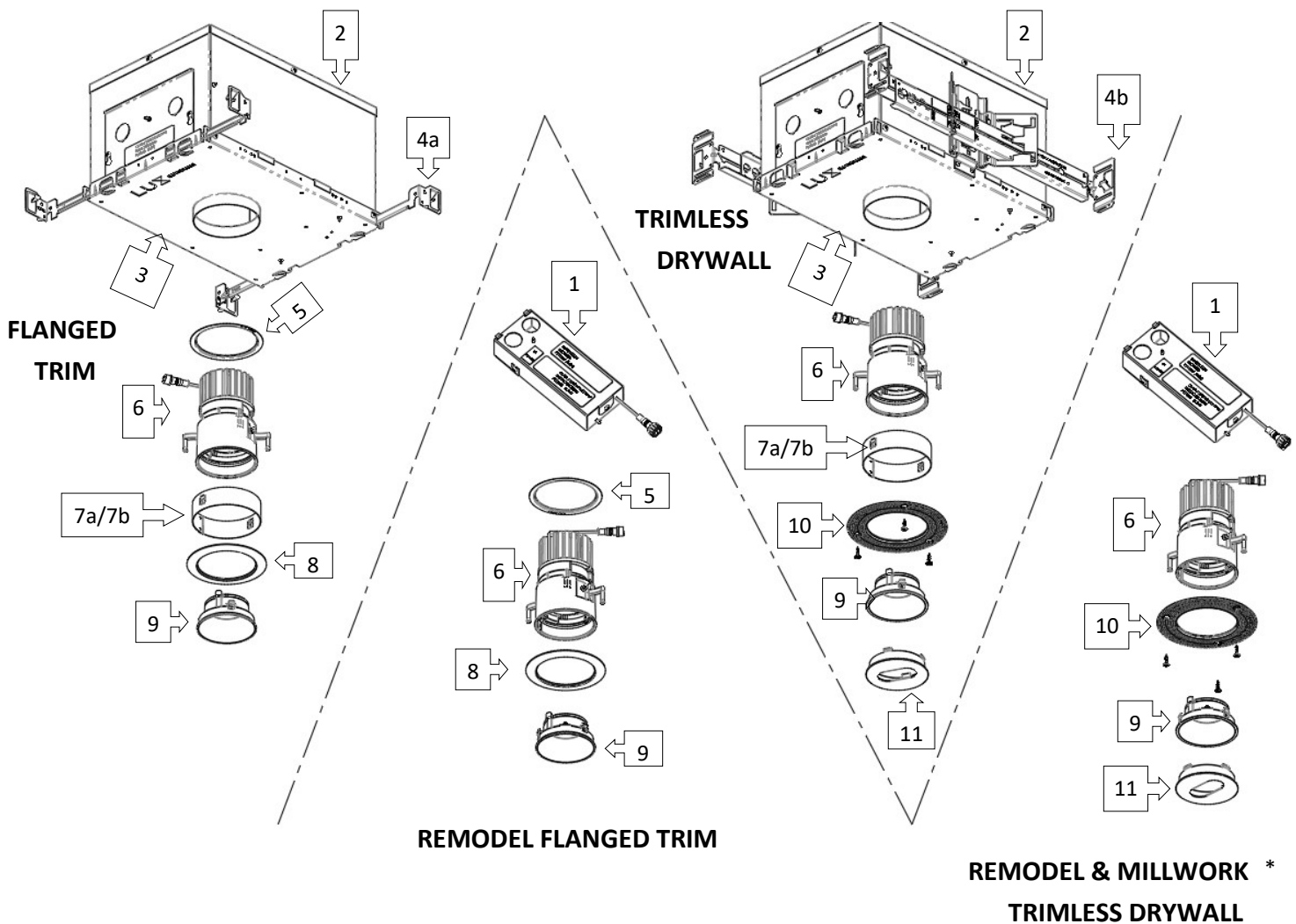

* See separate instruction sheet for Millwork installation kit

LaYR 2.0 Fixed Round Downlight

INSTALLATION TYPES

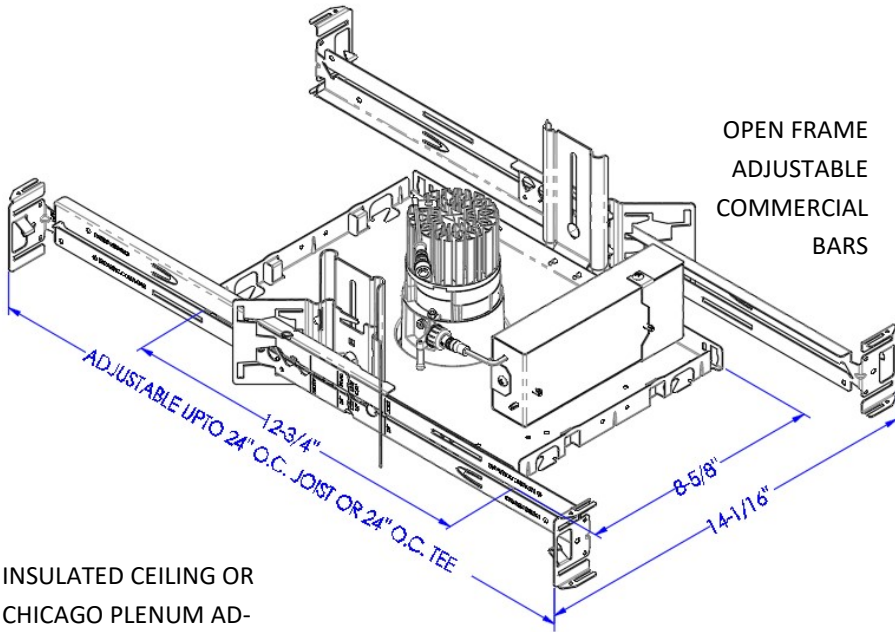

INSULATED CEILING OR
CHICAGO PLENUM AD-
JUSTABLE COMMERCIAL
MOUNTING BARS

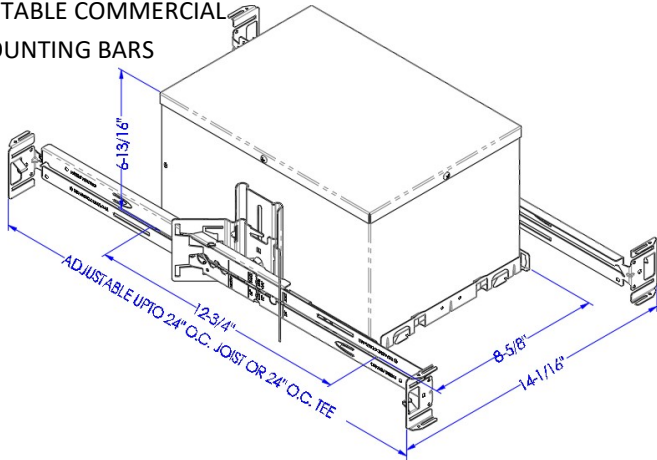

INSULATED CEILING OR
CHICAGO PLENUM
STANDARD MOUNT-
ING BARS

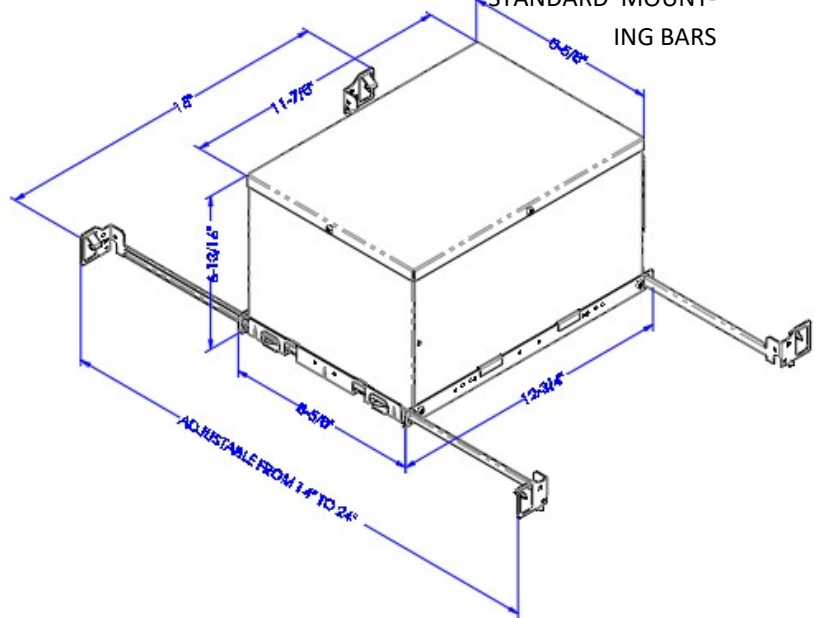

OPEN FRAME
STANDARD
MOUNTING BARS

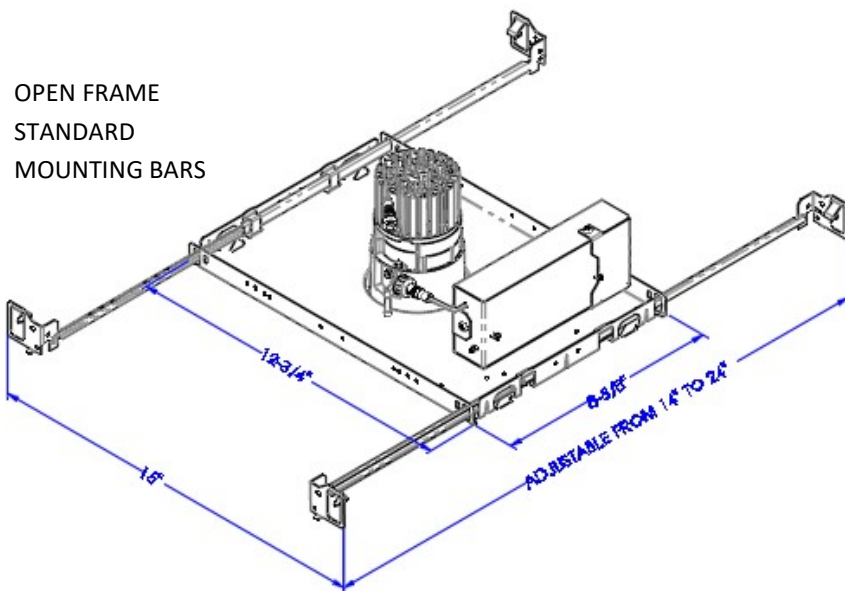

LaYR 2.0 Fixed Round Downlight

MOUNTING OPTIONS

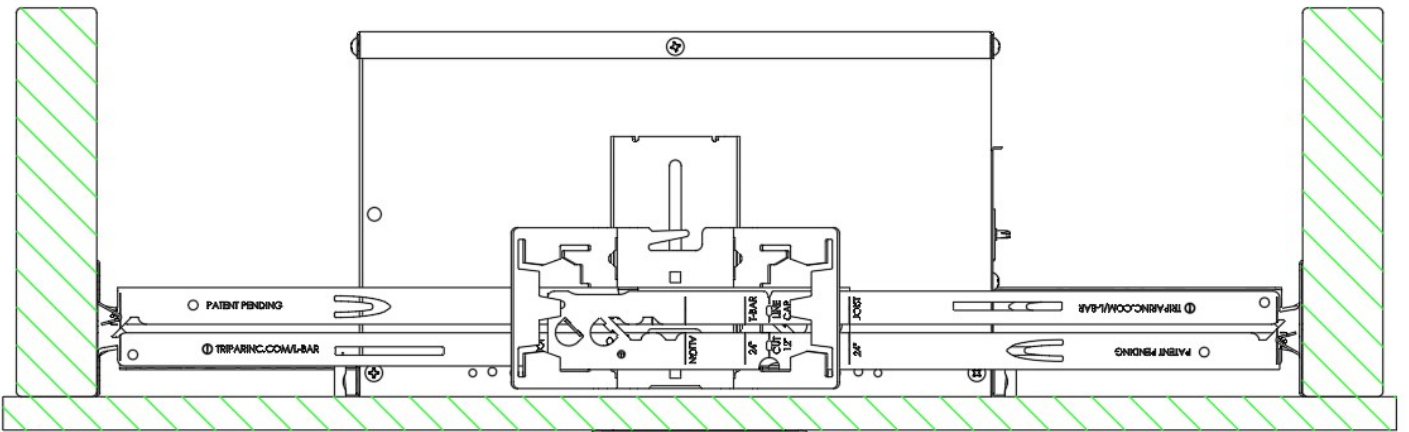
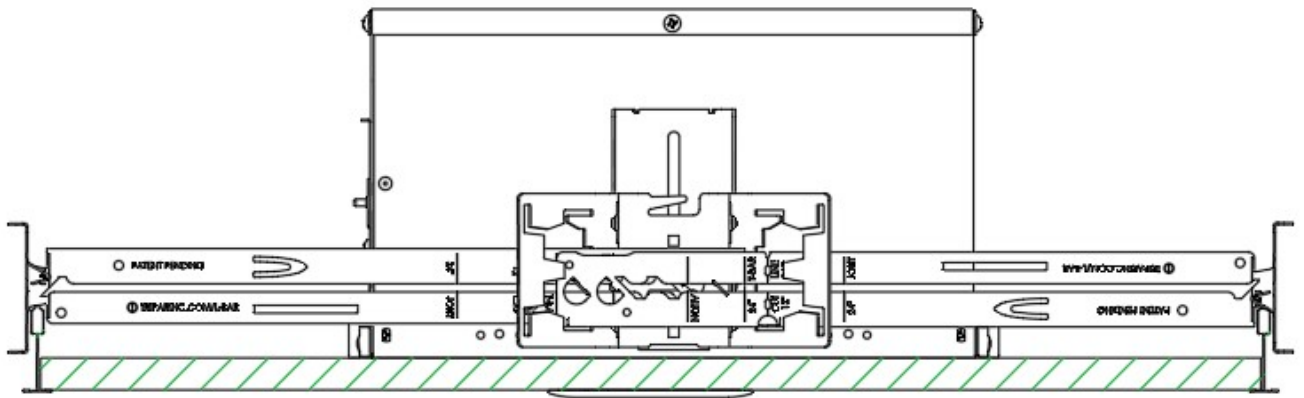
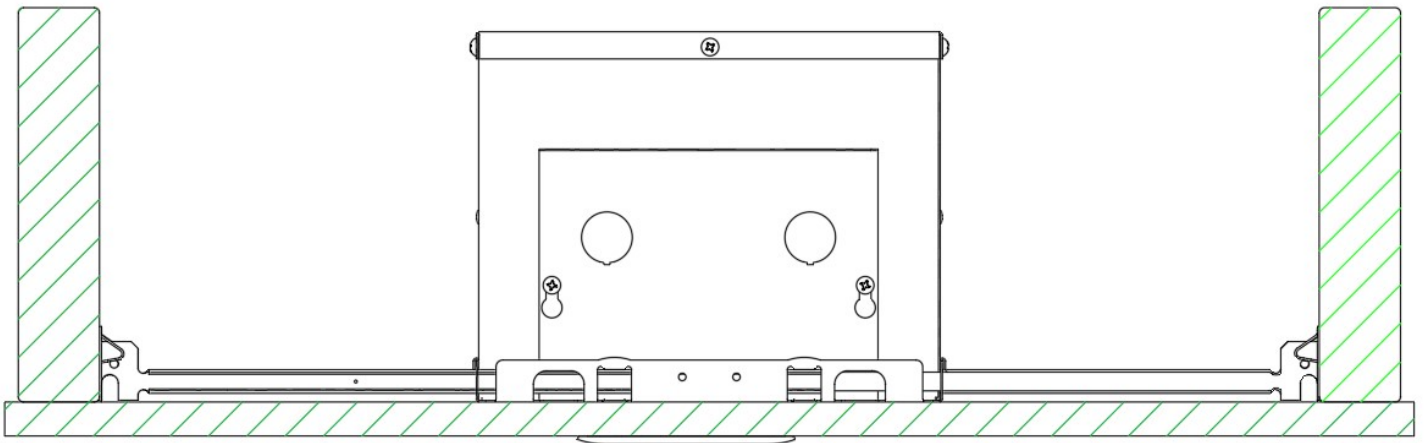
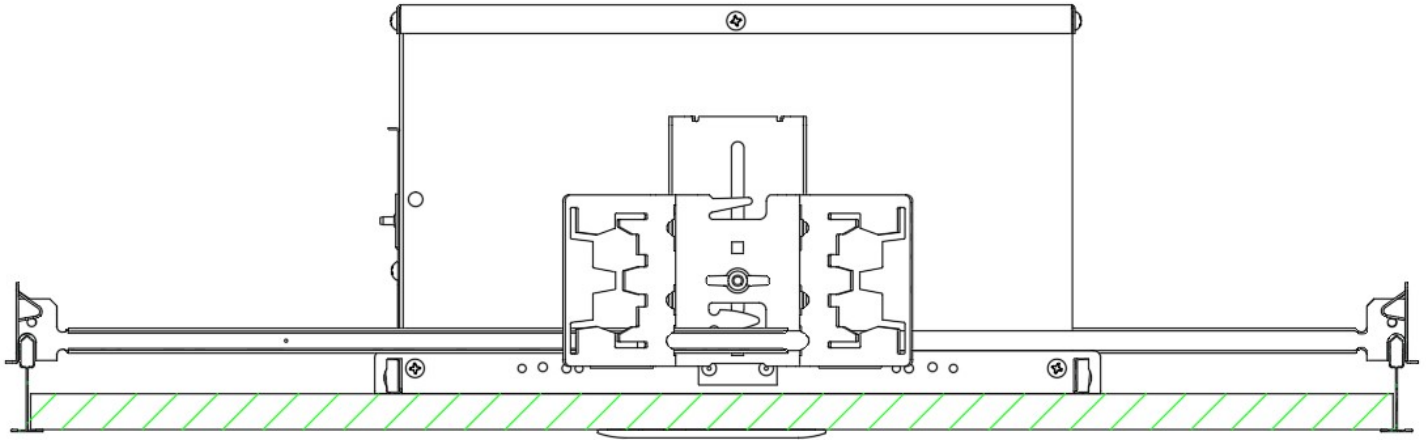

STANDARD ADJUSTABLE HANGER BARS

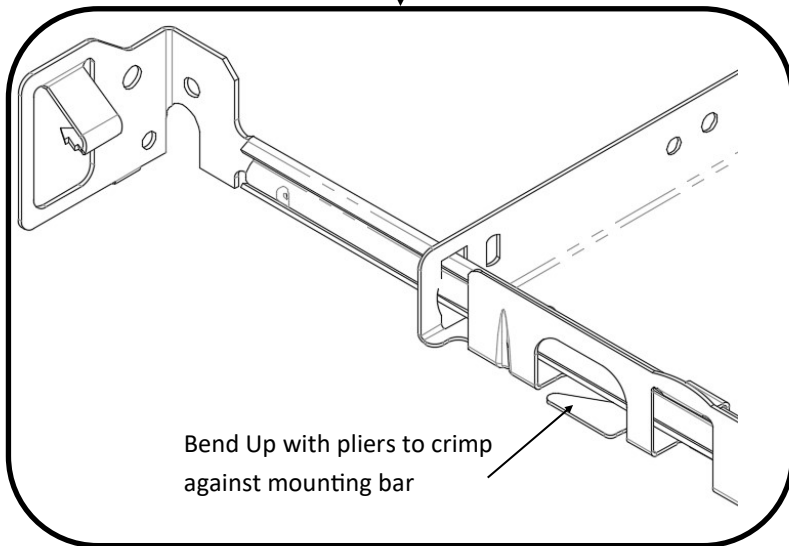
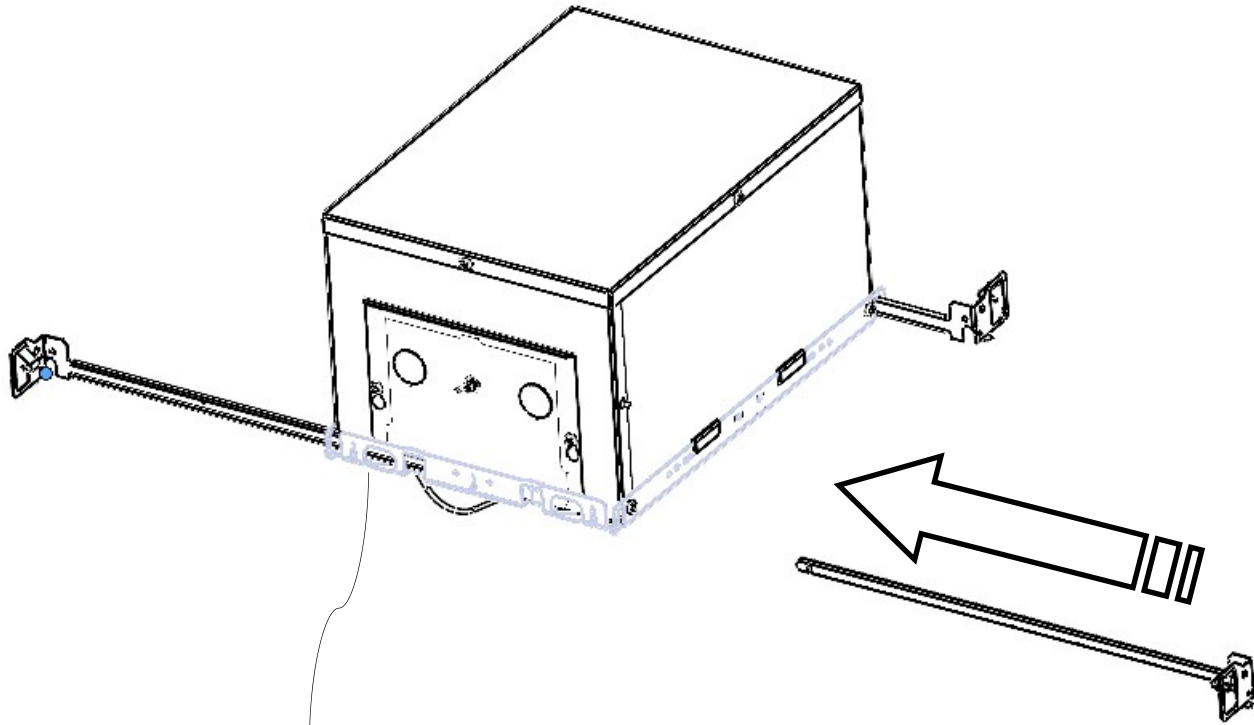

Separate the separately packaged hanger bars

Insert the hanger bars in the dedicated end opening of the ceiling pan

Re-engage bars into each other, collapsing them to facilitate mounting in the ceiling

After attaching and positioning the fixture in the ceiling, bend up the locking tab to fix it place.

MOUNT HOUSING IN CEILING

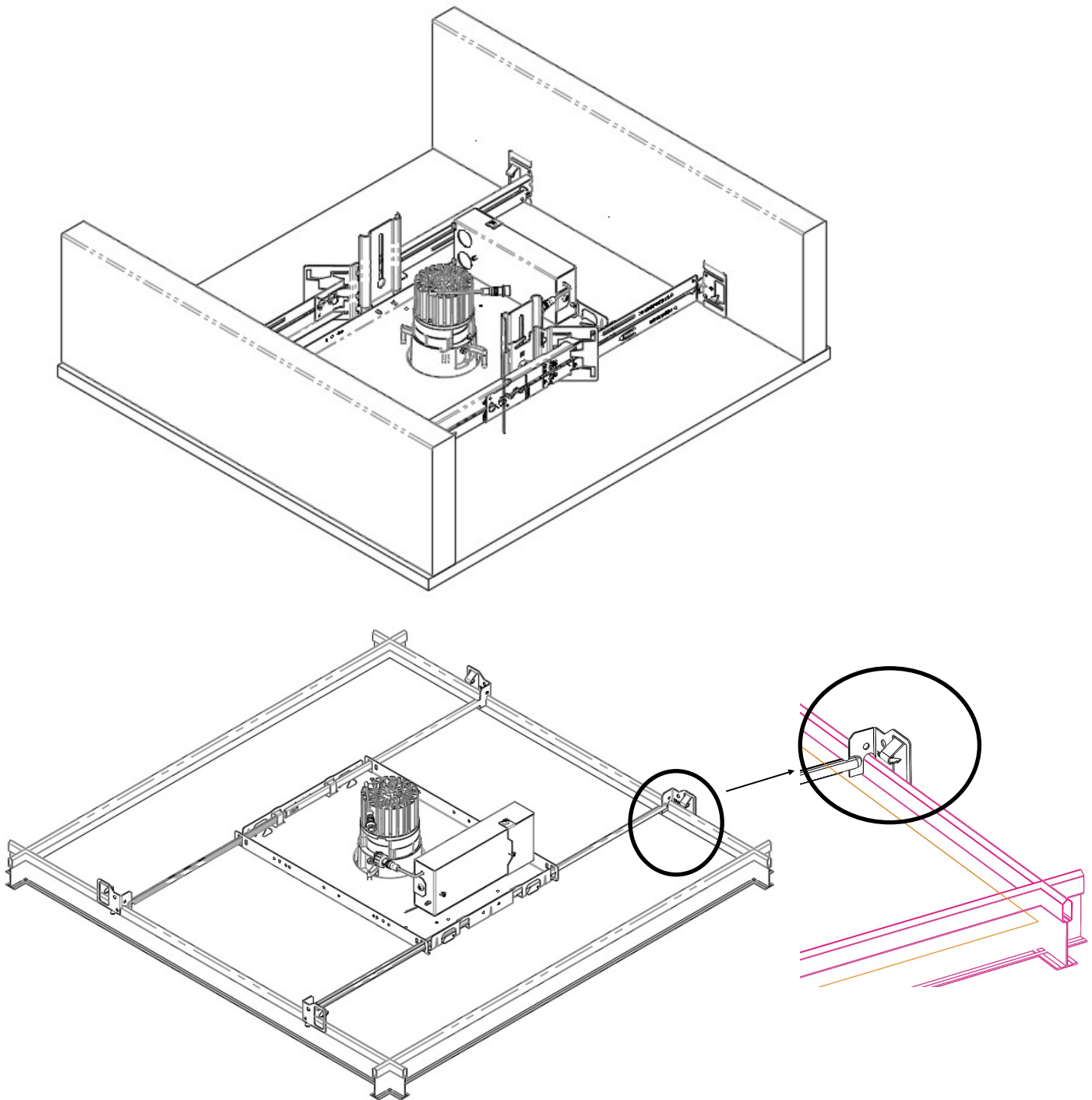

Pan aperture edge to be flush and even with the finished ceiling surface

CEILING PREPARATION

Alternate butterfly mounting bracket below is used when ordered with ACB

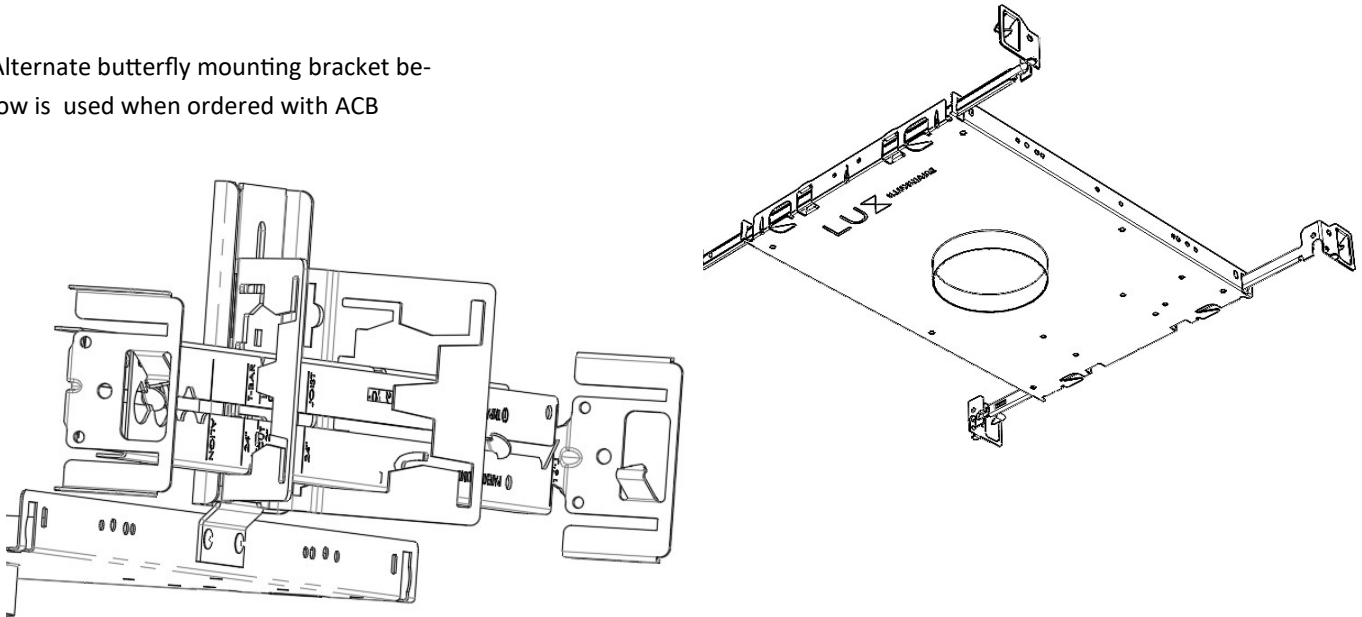

Open Frame [OF] , Insulated Ceiling [IC] or, Chicago Plenum [CP] versions will FIRST install ceiling pans [shown above] in plenum prior to fitting ceiling material about fixture aperture.

Remodel [RM] will fit through cutout directly.

Cut hole size in gypsum or tile ceiling

Trimless Millwork will need a hole that follows a separately supplied template.

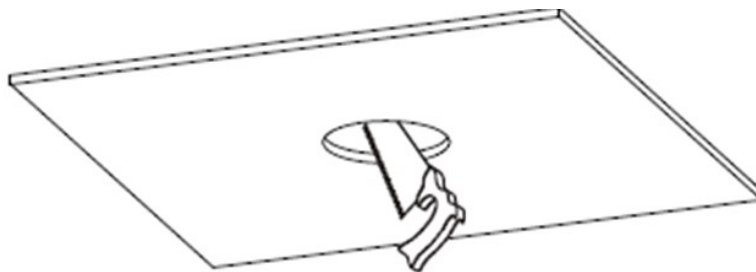

OF/IC/CP 2inch ROUND CUTOUT = 3.5" diameter

RM [remodel] 2inch ROUND CUTOUT = 3.375 "diameter

HOUSING INSTALLATION

1. Fixture housing mounting will vary by ceiling type:
 - Nailer bars are supplied and used as typical mounting means in drywall applications. They fit a range between 14"–22.5". Install as mating pairs in either the slots in the ceiling pan or in butterfly brackets
 - C-channels [not supplied] are an optional way to mount in drop ceiling applications
2. Adjust height of fixture so that aperture collar is flush with room side of ceiling
 - Raise ceiling pan prior to nailing mounting bars into position so that the bottom edge of the aperture is flush and even with the finished ceiling plane
3. Install power feed to remote driver box or internally mounted driver in IC or CP fixtures. IC fixtures will need power feed to pass through K/O hole in access plate and have enough slack for servicing drivers below ceiling aperture.
4. Extend quick connector out of aperture in preparation to connect with mating connector on light engine inserted into aperture from room side

LIGHT ENGINE INSTALLATION

1. Bring light engine assembly in close proximity to ceiling plate aperture:
 - Have an T10 torx head screwdriver ready at hand
 - Ensure that swing-out mounting arms are tucked into their recesses in assembly prior to inserting light engine assembly into aperture
 - If application is drywall, first insert mud plate over light engine and then fix mud plate to ceiling with screws and insert mud plug for paint and spackle control.
 - If application is drop ceiling or **ReModel**, insert stamped CEILING RETENTION RING over light engine ensuring that the side labeled ROOM SIDE faces the room being illuminated and that the side labeled CEILING SIDE comes in contact with the ceiling surface.
2. Connect mating electrical connectors together
 - Screw together
3. Using torx screwdriver, rotate mounting arm screws from below until light engine is suspended in aperture. DO NOT OVERTIGHTEN
4. If application is drywall, fix mud plate to ceiling with screws [by others] and insert the disposable Mud/Paint Plug for spackle and paint entry prevention. Remove and dispose of this plug when ready to install the BAFFLE which is to be separately safeguarded in its packaging until this moment.
5. If the application is a drop ceiling, place the Trim Ring over Baffle and insert both into aperture orienting springs to face mating regresses in light engine.

View from below looking into luminaire inserted into ceiling until the stamped CEILING RETENTION RING is pressed against ceiling surface in a TRIM FLANGE version.

The TRIMLESS DRYWALL version functions similarly but with a MUD RING .

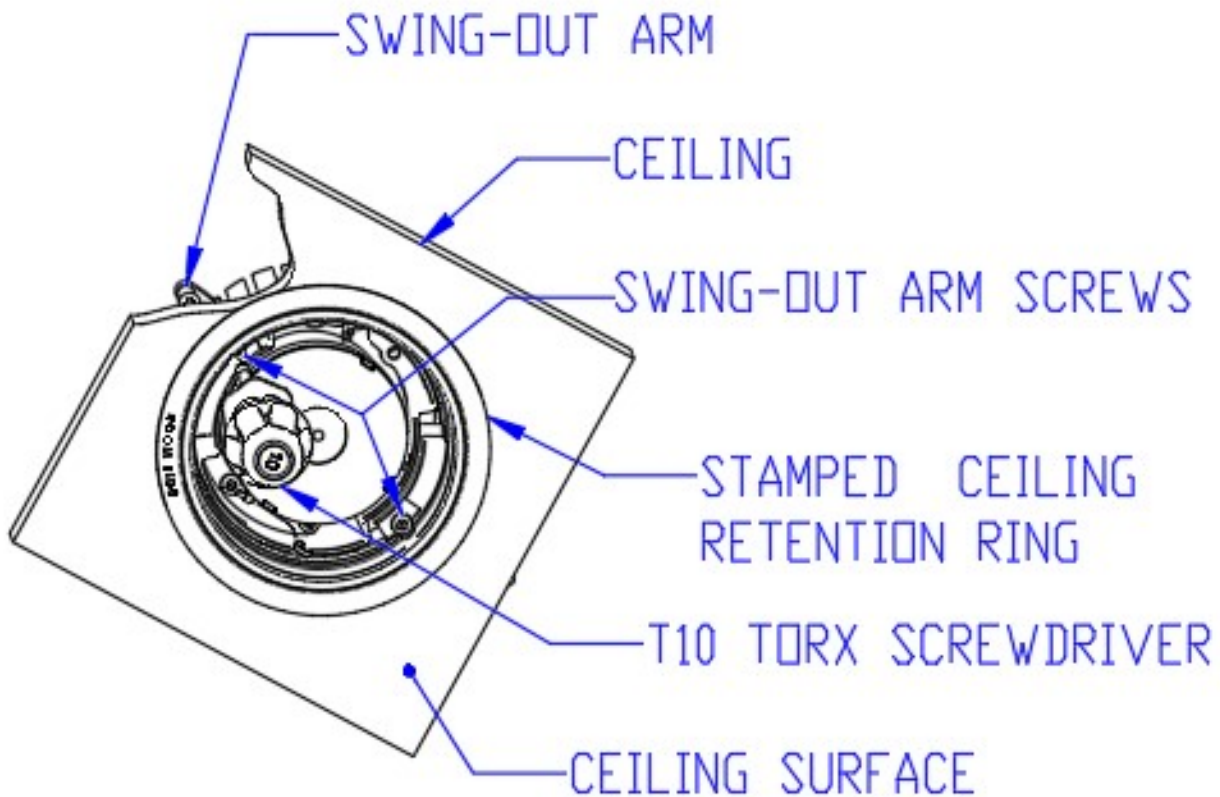

Important: **DO NOT OVERTIGHTEN SCREWS.**

Fingertight pressure plus 1/4 turn will lock luminaire into position.

If power drivers are used, they should be set to minimal torque setting

LaYR 2.0 Fixed Round Downlight

Installation Instruction Sheet

DRIVER /HOUSING MOUNTING TYPES

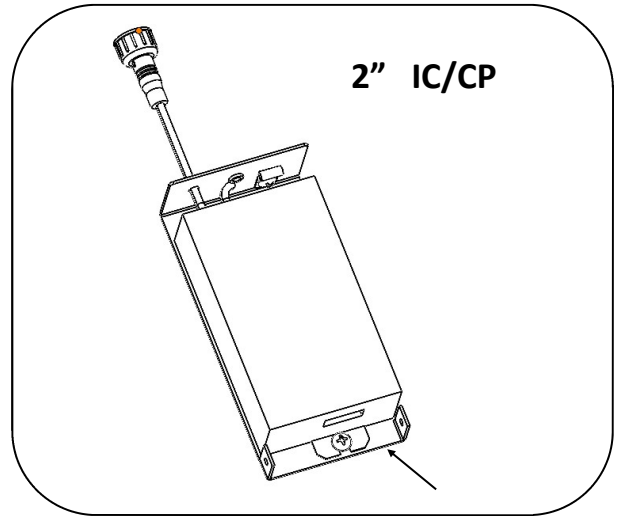
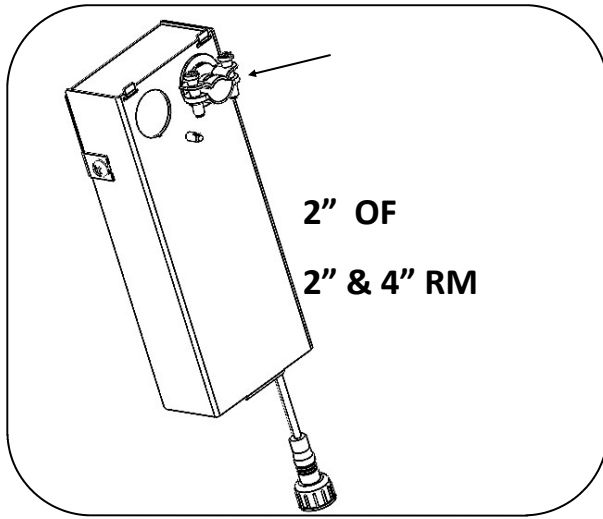

For special circuitry consult factory

LINE WIRE COLOR	CIRCUIT DESCRIPTION
BLK	CIRCUIT A—HOT
WHT	CIRCUIT A & B— NEUTRAL
RED	CIRCUIT B— HOT
GRN	GROUNDING
VLT	DIMMING CONTROL 1
GRY	DIMMING CONTROL 2
ORG	EHS or EHF—HOT
WHT/ORG	EHS or EHF— NEUTRAL

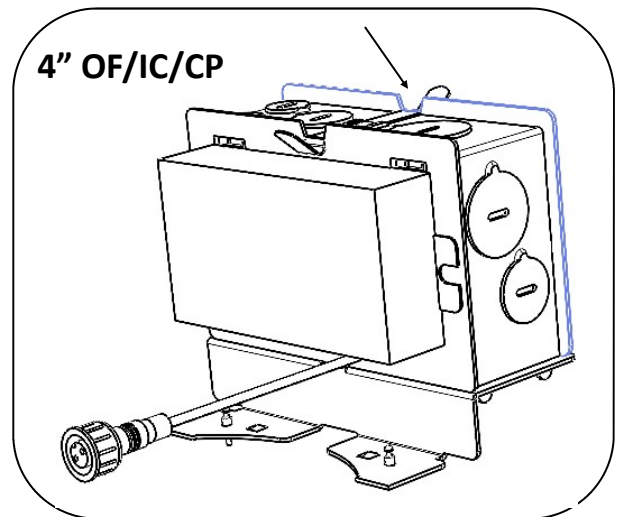

General Wiring Diagram

