

Installation Instruction Sheet

Linear Fixtures

INSTALLATION INSTRUCTIONS FOR JOINING AND SUSPENDING FIXTURES

WARNING

To reduce the risk of death, injury or property damage from fire, electric shock, cuts, abrasions, falling parts and other hazards:

- Service of the equipment must be performed by qualified service personnel.
- Installation and maintenance must be performed by a person familiar with the construction and operation of this product and any hazards involved. All applicable codes and ordinances must be followed.
- Read this document before installing, servicing or maintaining this equipment. These instructions do not cover all installation, service and maintenance situations. If your situation is not covered, or, if you do not understand these instructions or additional information is required, contact Lux Illuminaire or your local agent.
- Read and follow all warnings and instructions provided by the LED manufacturer.

WARNING

- Before installing, servicing or maintaining this equipment, follow these general precautions. To reduce the risk of electrocution:
- Make sure the equipment is properly grounded.
- Always de-energize the circuit and/or equipment before connecting to, disconnecting from or servicing the equipment.

To prevent luminaire row from over-current:

- By adding the input current of each luminaire section marked on the luminaire, the total current per power feed must not exceed the maximum line wire amperage marked on the luminaire and the power feed cord/wire amperage rating whichever is the least.

To reduce the risk of fire:

- Keep material away that can burn from hot LEDs.
- Make sure LED boards are correctly installed.
- Use supply conductors with a minimum installation temperature rating as specified on equipment.

To reduce the risk of personal injury from cuts, abrasions or falling parts:

- Wear gloves to prevent cuts or abrasions from sharp edges when removing from carton, handling and maintaining this equipment.
- Do not use abrasive materials, glass cleaners or other solvents on reflector or lens. These substances may damage equipment and cause parts to eventually break and fall.
- Do not install a damaged fixture.

Typical Mounting Configurations

Linear Fixtures

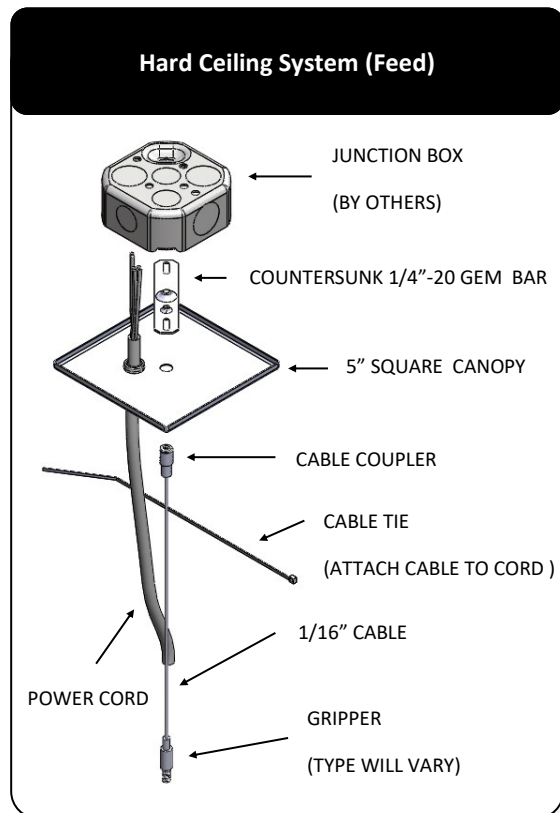
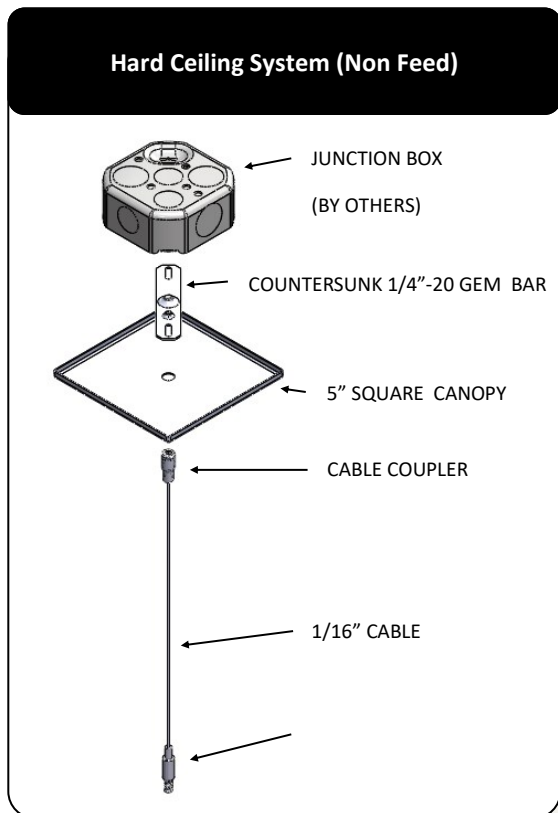
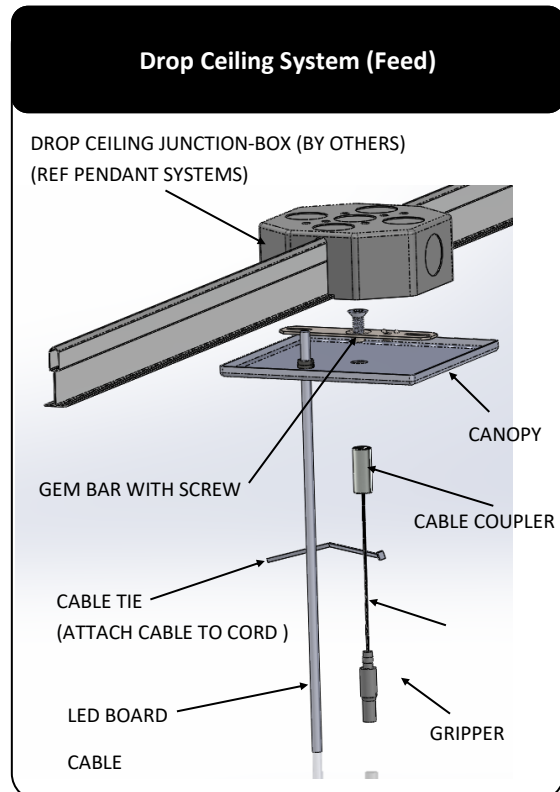
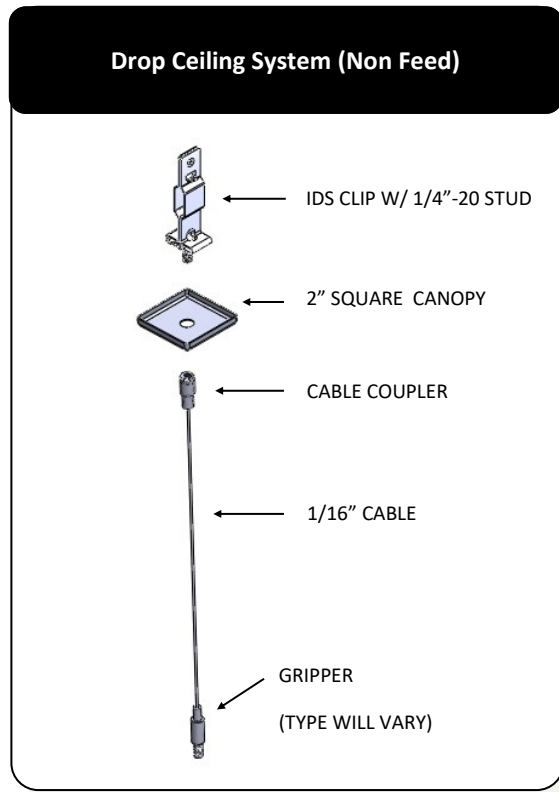

Installation Instruction Sheet

Linear Fixtures

INSTALLATION INSTRUCTIONS FOR POWER FEED

If not installed on fixture, insert power cord through feed hole on the first [Starter] fixture and plug into harness connectors. Cap off any unused feed holes with supplied plug.

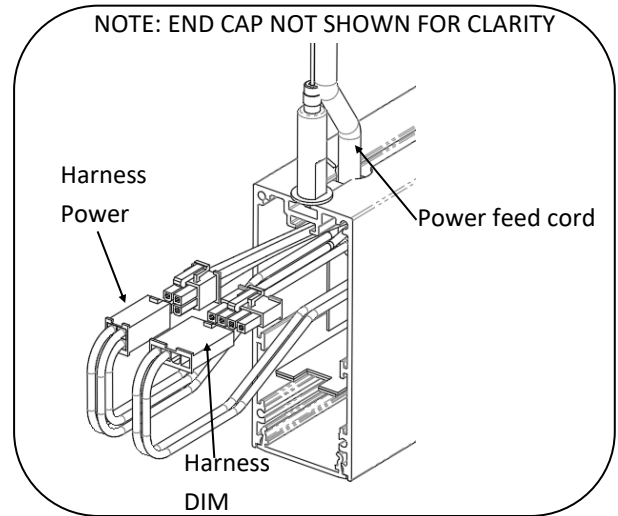

For special circuitry consult factory	
LINE WIRE COLOR	CIRCUIT DESCRIPTION
BLK	CIRCUIT A—HOT
WHT	CIRCUIT A & B— NEUTRAL
RED	CIRCUIT B— HOT
GRN	GROUNDING
VLT	DIMMING CONTROL 1
PINK OR GRY	DIMMING CONTROL 2
ORG	EHS or EHF—HOT
WHT/ORG	EHS or EHF— NEUTRAL

POWER FEED CORD COLOR	
14x3 BLK/WHT/GRN	CIRCUIT A & EMERGENCY
14x4 BLK/WHT/GRN/RED	CIRCUIT B, OR CIRCUIT A W/ EHS
18x5 BLK/WHT/GRN/VLT/GRY	CIRCUIT A & EMERGENCY & DIM

General Wiring Diagram

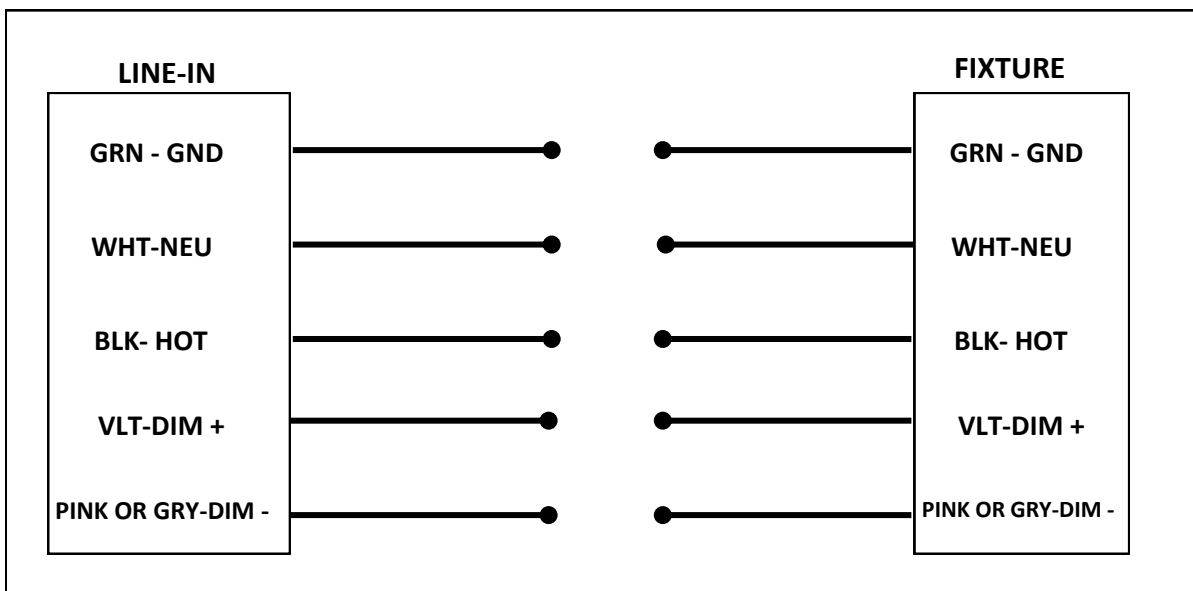

INSTALLATION INSTRUCTIONS FOR JOINING AND SUSPENDING FIXTURES

***DO NOT MAKE JOINT CONNECTIONS BEFORE HANGING, OR BUILD CONFIGURATIONS ON THE GROUND! EACH PIECE MUST BE HUNG INDIVIDUALLY!**

Individual and Starter fixtures are suspended at both ends through aircraft cable going through gripper. Screw cable gripper into the exposed thread of captured 1/4-20 stud. Adjust fixture distance from ceiling through gripper. Excess aircraft cable can be snipped off at gripper's side exit, after leveling fixture to desired height .

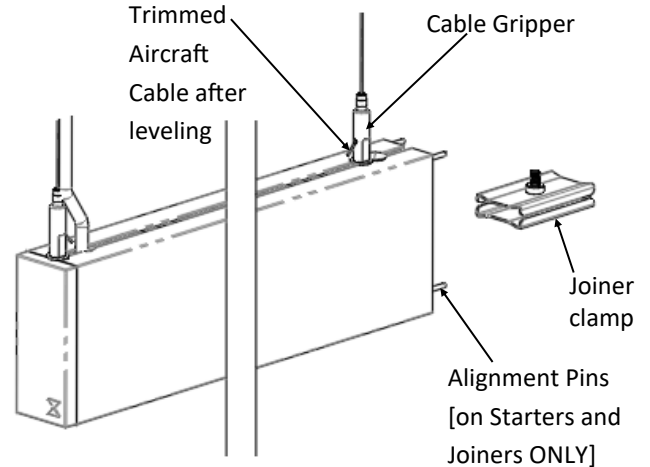

Joiner and Ender fixtures are suspended by one aircraft cable at the far end and depend on the Starter fixture to first be installed. After suspending a Joiner or Ender adjacent to Starter, first connect wiring harness and tuck in fixture. Then align joiner clamp bracket as shown below, letting it slide over the internal housing features. Continue to draw fixtures together so that the four alignment pins engage and until the housings squarely make contact.

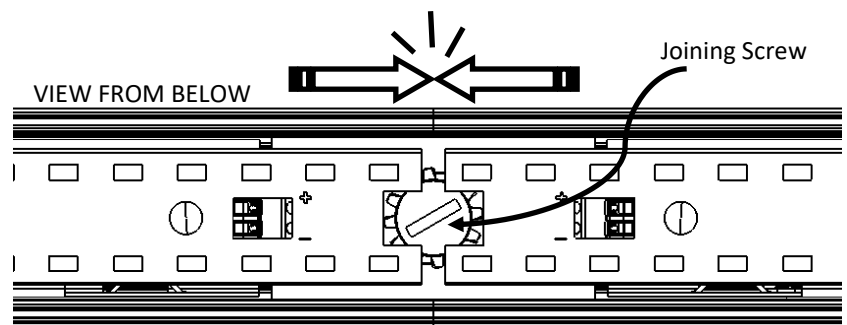
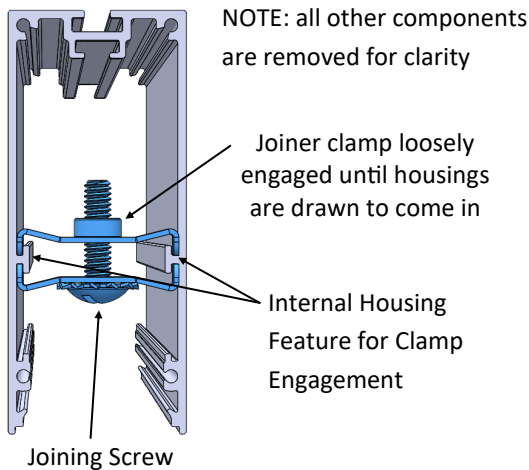
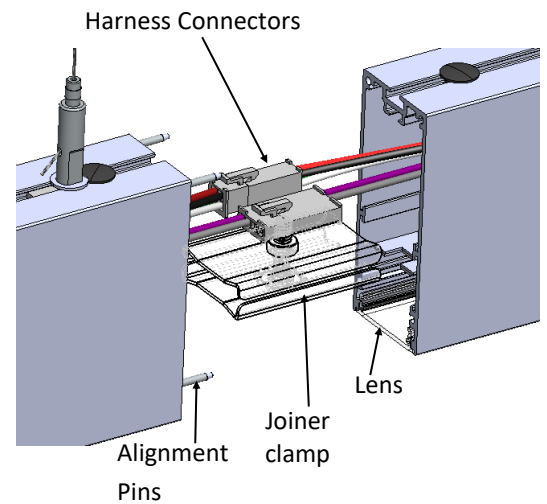

From below, with the lens removed, the joiner bracket screw should be visible and self-centered about the gap between and behind adjacent LED boards . Fasten screws while ensuring that housings are still squarely in contact with each other to complete the joining of each subsequent continuous row fixture. Re-insert lens into its position.