

Installation Instruction Sheet

Linear Fixtures

INSTALLATION INSTRUCTIONS FOR JOINING AND SUSPENDING FIXTURES

WARNING

To reduce the risk of death, injury or property damage from fire, electric shock, cuts, abrasions, falling parts and other hazards:

- Service of the equipment must be performed by qualified service personnel.
- Installation and maintenance must be performed by a person familiar with the construction and operation of this product and any hazards involved. All applicable codes and ordinances must be followed.
- Read this document before installing, servicing or maintaining this equipment. These instructions do not cover all installation, service and maintenance situations. If your situation is not covered, or, if you do not understand these instructions or additional information is required, contact Lux Illuminaire or your local agent.
- Read and follow all warnings and instructions provided by the LED manufacturer.

WARNING

- Before installing, servicing or maintaining this equipment, follow these general precautions. To reduce the risk of electrocution:
- Make sure the equipment is properly grounded.
- Always de-energize the circuit and/or equipment before connecting to, disconnecting from or servicing the equipment.

To prevent luminaire row from over-current:

- By adding the input current of each luminaire section marked on the luminaire, the total current per power feed must not exceed the maximum line wire amperage marked on the luminaire and the power feed cord/wire amperage rating whichever is the least.

To reduce the risk of fire:

- Keep material away that can burn from hot LEDs.
- Make sure LED boards are correctly installed.
- Use supply conductors with a minimum installation temperature rating as specified on equipment.

To reduce the risk of personal injury from cuts, abrasions or falling parts:

- Wear gloves to prevent cuts or abrasions from sharp edges when removing from carton, handling and maintaining this equipment.
- Do not use abrasive materials, glass cleaners or other solvents on reflector or lens. These substances may damage equipment and cause parts to eventually break and fall.
- Do not install a damaged fixture.

Typical Mounting Configurations

Linear Fixtures

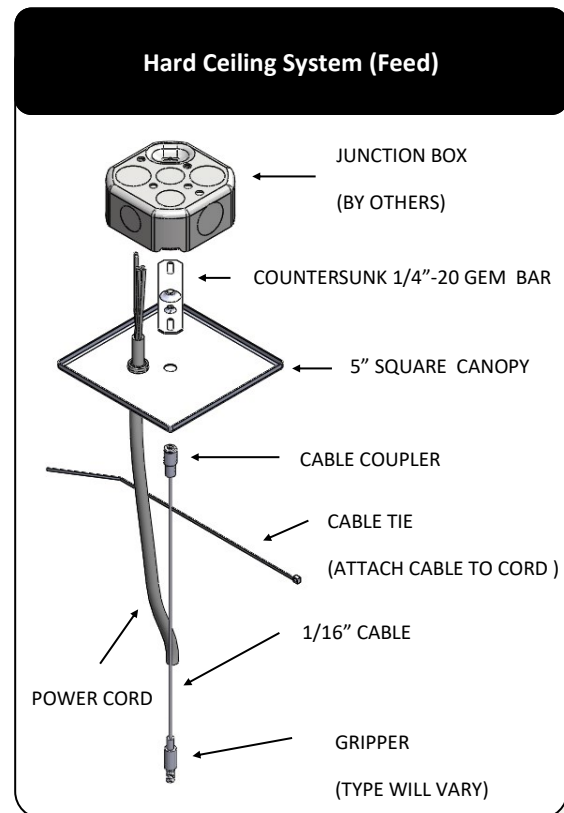
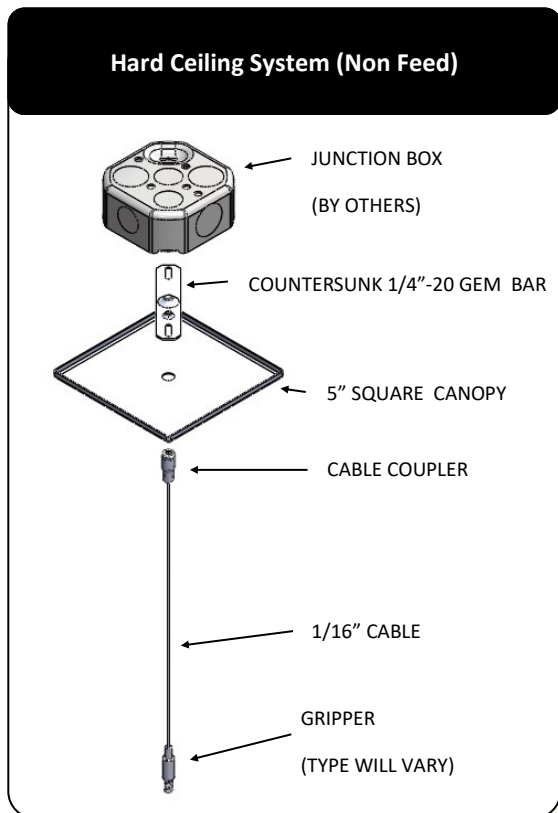
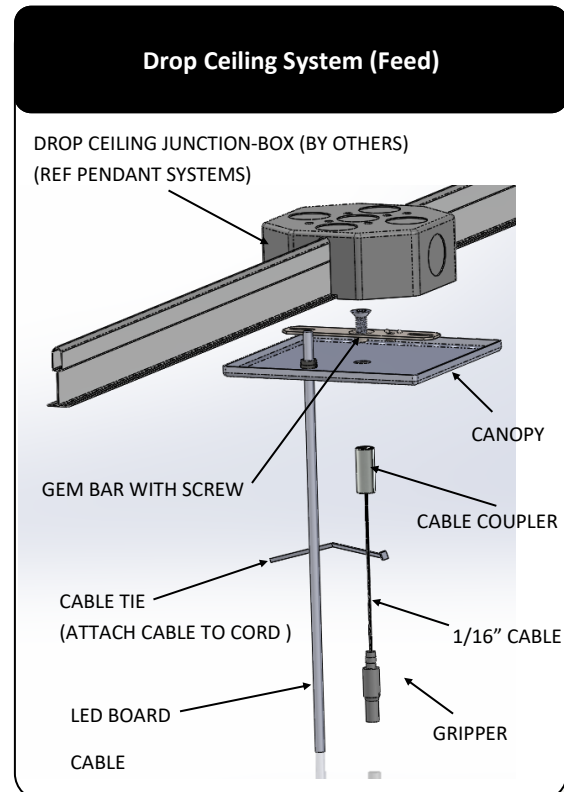
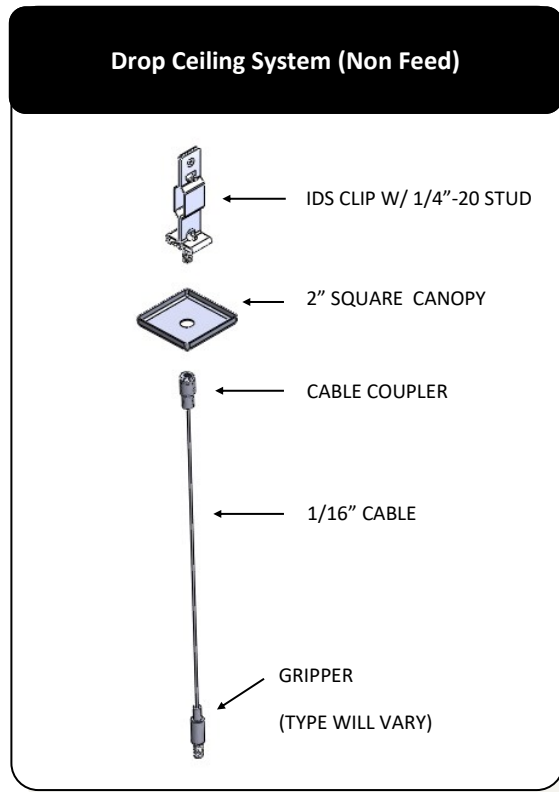

Installation Instruction Sheet

Linear Fixtures

INSTALLATION INSTRUCTIONS FOR POWER FEED

If not installed on fixture, insert power cord through feed hole on the first fixture and plug to through harness connectors. Plug (supplied) any unused feed holes.

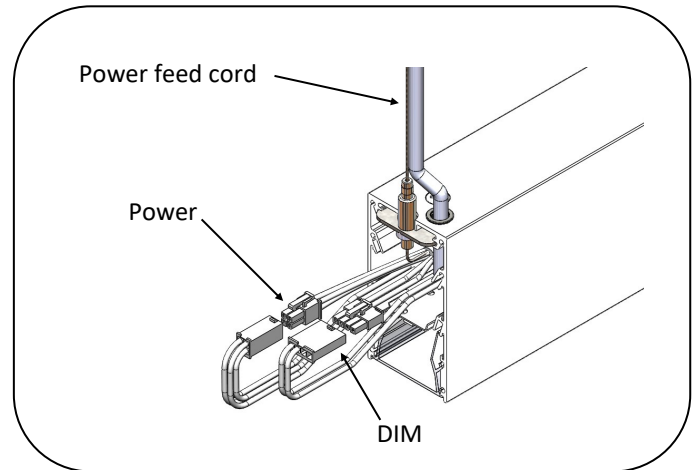

| For special circuitry consult factory | |
|---------------------------------------|------------------------|
| LINE WIRE COLOR | CIRCUIT DESCRIPTION |
| BLK | CIRCUIT A—HOT |
| WHT | CIRCUIT A & B— NEUTRAL |
| RED | CIRCUIT B— HOT |
| GRN | GROUNDING |
| VLT | DIMMING CONTROL 1 |
| PINK OR GRY | DIMMING CONTROL 2 |
| ORG | EHS or EHF—HOT |
| WHT/ORG | EHS or EHF— NEUTRAL |

| POWER FEED CORD COLOR | |
|--------------------------|--------------------------------|
| 14x3 BLK/WHT/GRN | CIRCUIT A & EMERGENCY |
| 14x4 BLK/WHT/GRN/RED | CIRCUIT B, OR CIRCUIT A W/ EHS |
| 18x5 BLK/WHT/GRN/VLT/GRY | CIRCUIT A & EMERGENCY & DIM |

General Wiring Diagram

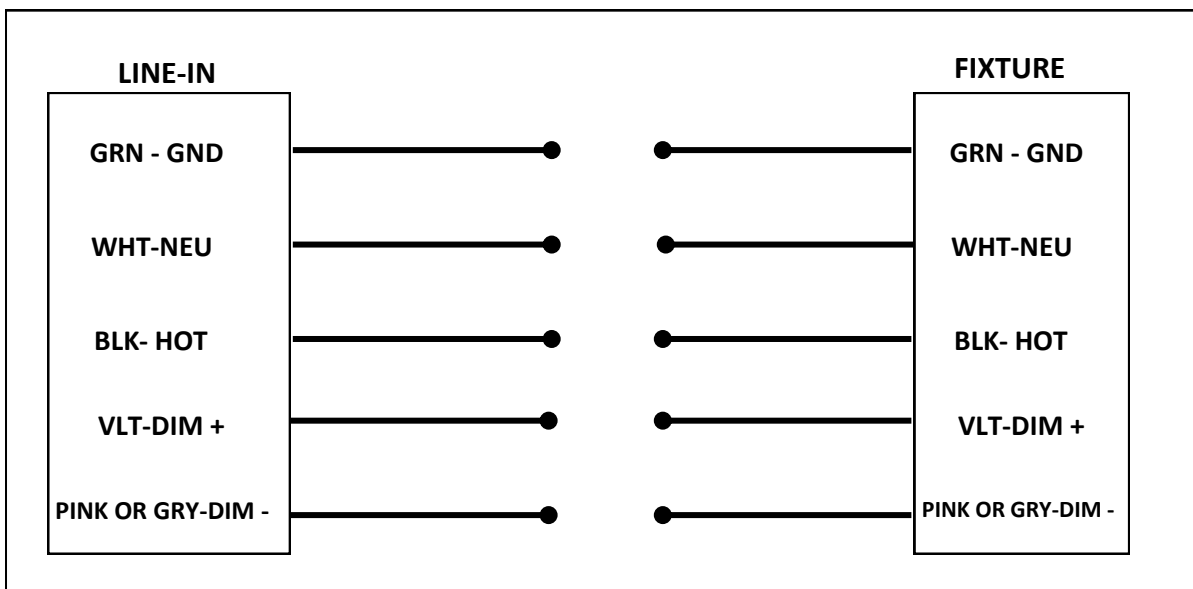

INSTALLATION INSTRUCTIONS FOR JOINING AND SUSPENDING FIXTURES

***DO NOT MAKE JOINT CONNECTIONS BEFORE HANGING, OR BUILD CONFIGURATIONS ON THE GROUND! EACH PIECE MUST BE HUNG INDIVIDUALLY!**

Use hanger bracket located at the end of the fixture to support fixture.

Screw cable gripper/stem into the outside thread position of hanger at the end of a row **OR** in the middle thread position if joining fixtures together.

Adjust fixture length from ceiling with cable gripper.

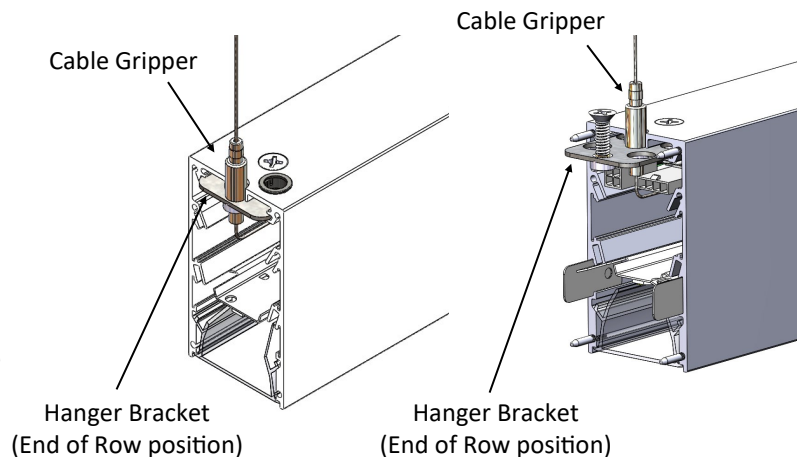

Use provided flathead screws to secure hanger bracket to fixture.

Remove power and dimming harness connectors from the fixture to attach to power cord. (Tuck in fixture)

Guides are used to align fixtures. Slide fixtures together and fasten supplied flathead screw to bracket.

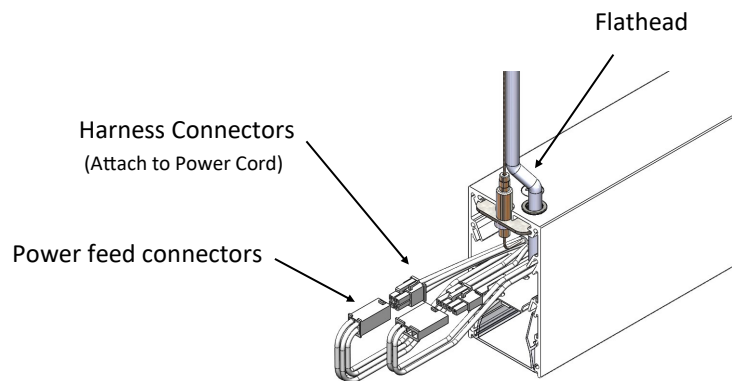

For row mounting fixtures attach male end of harness to female end of harness.

Fasten flathead screws on each fixture.

Fasten reflector tabs down with supplied screws to the joining fixture.

